

PITUMEC

THE PCON-E 215 CONCENTRIC UNDERREAMING SYSTEM

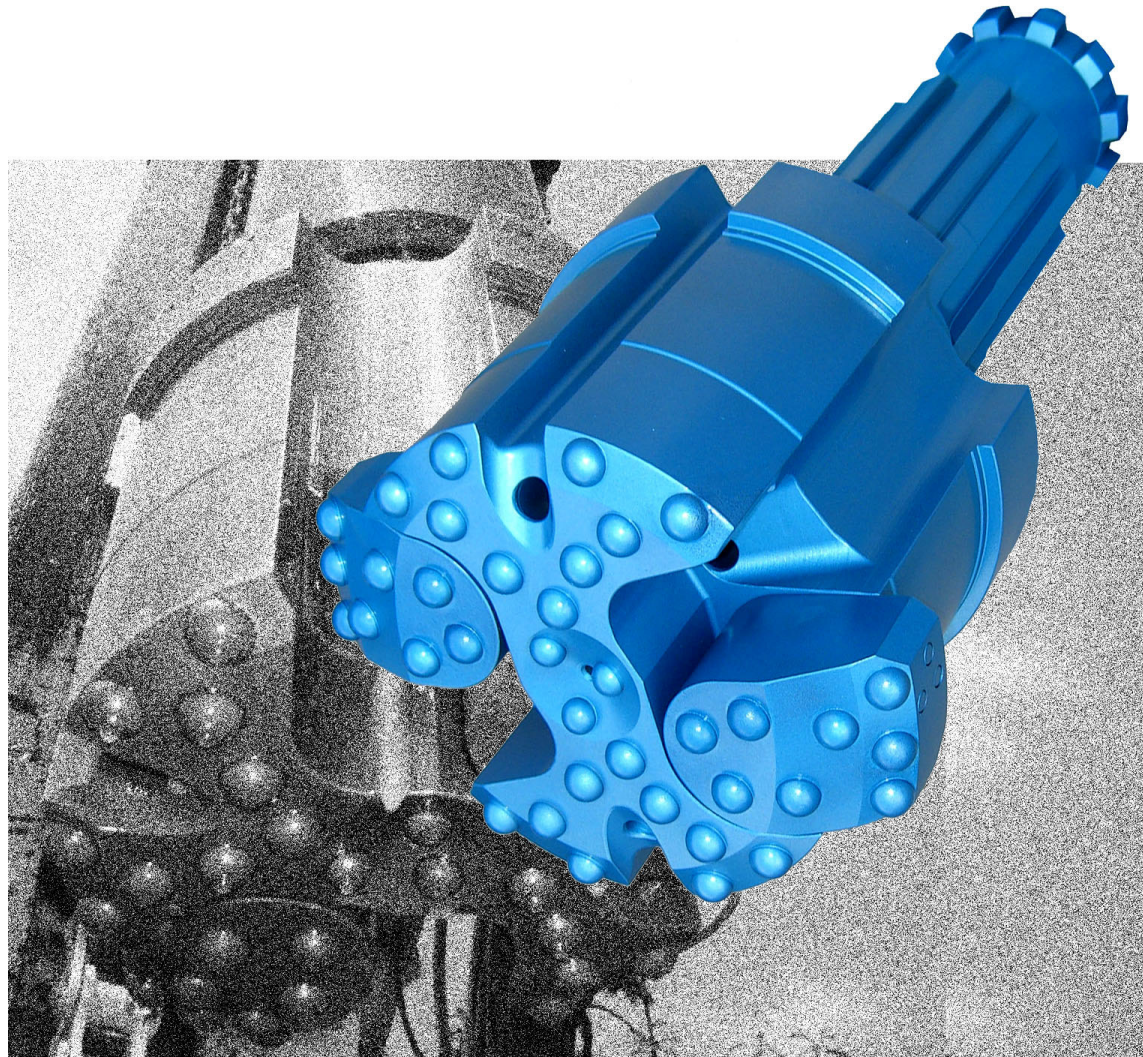

CASING SIZE 254MM OD X 240MM ID DRILLING DIA. 276MM

PNEUMEC PCON-E 215 CONCENTRIC UNDERREAMING SYSTEM

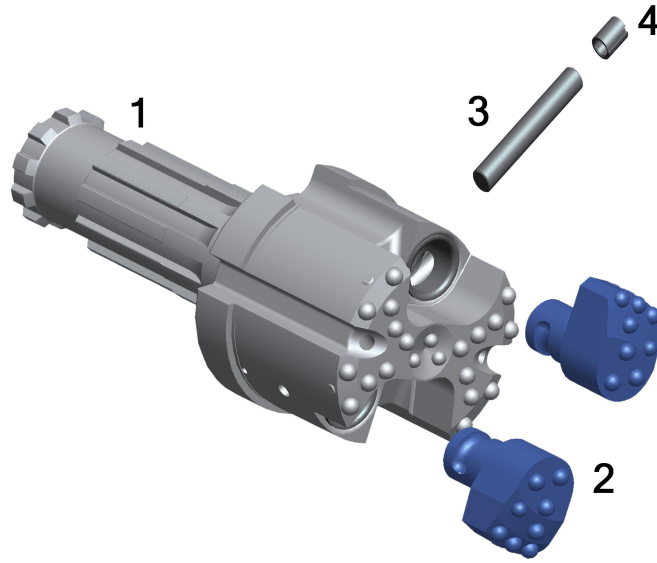

PCON-E 215 PARTS LIST

1.	DRIVER BIT DHD380 SHANK	UGD215380PCE
2.	REAMER(2)	UBS215PCE
3.	LOCKING PIN	USP21550PCE
4.	SPLIT PIN	USP21551PCE
5.	COMPLETE SYSTEM	UCS215380PCE

PCON-E 215 SPECIFICATIONS

UPPER BODY DIAMETER	236MM	CLOSED DIAMETER	215MM
REAMING DIAMETER	276MM	CASING SIZE	254MM OD X 240MM ID
SYSTEM LENGTH	590MM	SYSTEM WEIGHT	90KG

PCON-E 215 CASING SHOES

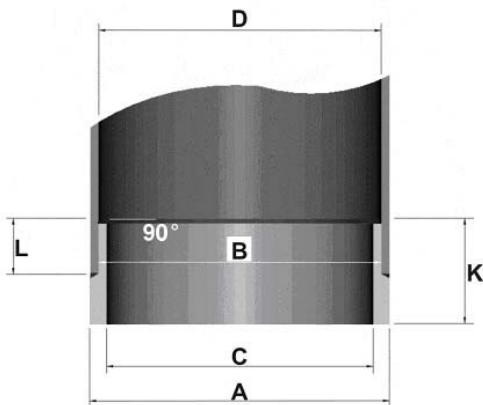

DIA. A	254MM
DIA. B	236MM
DIA. C	218MM
DIA. D	240MM
L	44MM
K	95MM



PNEUMEC COMPANY LIMITED

1st Floor, Tin On Sing Comm. Bldg., 41-43 Graham St. Central, H.K.

Tel : (852) 2180 9922

Fax : (852) 2180 9982

Website : www.pneumec.com

email : info@pneumec.com